

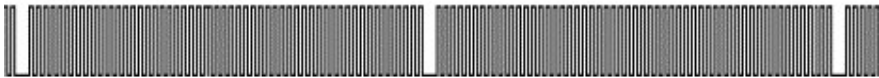

2. The signal analysis of Camshaft Angle Sensor

The camshaft angle sensor doesn't have an important effect on engine vibration or stall. But vehicles that use direct injection or TCS(Traction Control System) must recognize individual cylinder, so camshaft sensor has a big influence on the vehicle. Most of conventional vehicles use camshaft angle sensor with crankshaft angle sensor, so we will explain not only basic principle but also how to control camshaft angle sensor with crank angle sensor in ECU.

5. Troubles

| 1. Malfunction of camshaft sensor | |
|-----------------------------------|---|
| Cause of trouble | Malfunction of camshaft sensor or wiring circuit failure(Signal, Power supply line) |
| Counter action | Healing by cause of trouble Camshaft sensor replace Wiring circuit repair |
| Engine state | There is no problem in idle state but surging is taken place when acceleration. The vehicle which use TCS(Traction Control System) may not start. |
| Signal view | <p>Crank angle signal</p>  <p>CAM angle signal (no signal variation)</p>  |

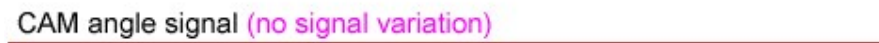
| 2. Camshaft signal is always constant | |
|---------------------------------------|---|
| Cause of trouble | Trouble detection more than one of the followings Abnormal camshaft sensor Bad connecting of camshaft sensor Camshaft sensor signal, ground and power supply line bad connecting or short to ground or battery |
| Counter action | Healing by cause of trouble Camshaft sensor replace Camshaft sensor wiring circuit repair |
| Engine state | There is no problem in idle state but surging is taken place when acceleration. The vehicles that use TCS(Traction Control System) may not start. |
| Signal view | <p>Crank angle signal</p>  <p>CAM angle signal (no signal variation)</p>  |

3. Too many camshaft sensor signal during 1 cycle

Cause of trouble

Camshaft angle recognition by electrical noise

Counter action

Healing by cause of trouble

3.1 Separate wiring of ignition system, camshaft sensor ground and signal line from other wiring(TCU system etc.). After that make a shield the separated wirings(3[cm] front of ECU) and then keep away camshaft sensor from wiring of ignition system.

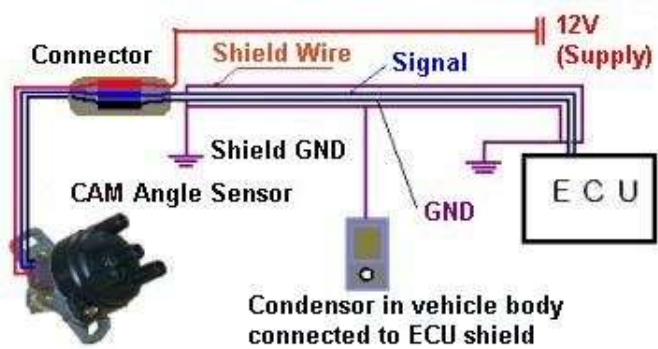

< Optical type >

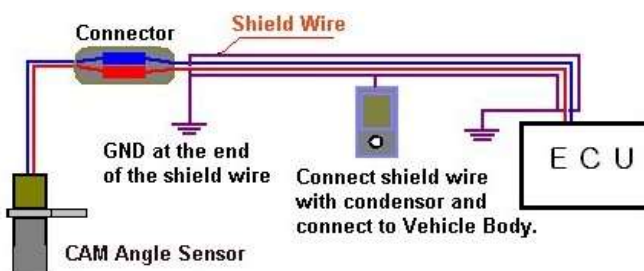

< Hall type or Magnetic type >



Engine state

During idle state, engine vibration is intermittently taken place. The backfire is occurred with LPG vehicle.

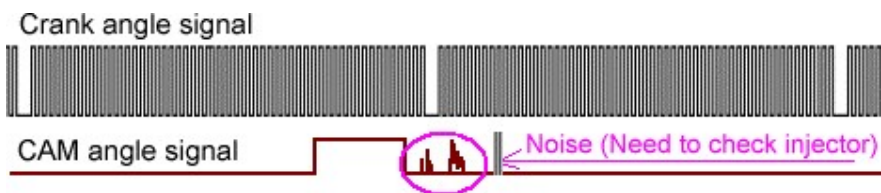
Signal view

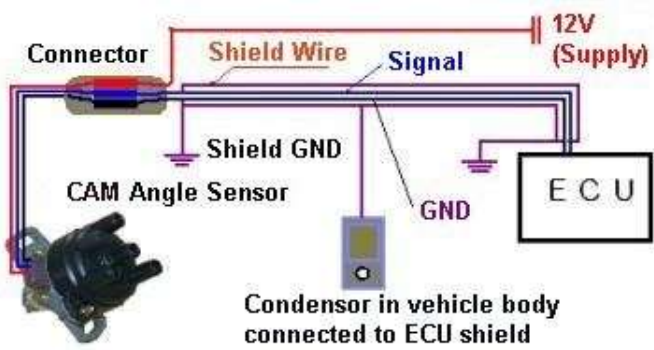
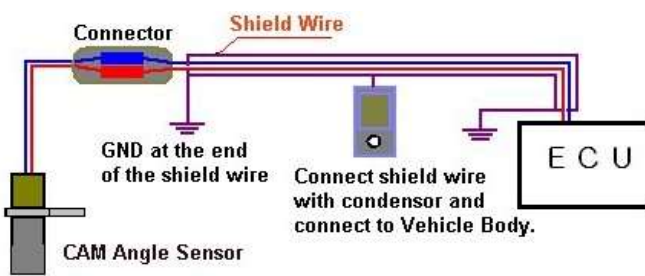

Reference: Check that ECU cut injection or ignition with noise detection. If it is not cut, ECU control is normal. C_CAM_THD is criteria for normal camshaft angle detection (About 0.5 ~ 2.5V).

| 4. Camshaft sensor phase is irregular. | |
|--|---|
| Cause of trouble | Camshaft angle recognition by electrical noise |
| Counter action | <p>Healing by cause of trouble</p> <p>4.1 Separate wiring of ignition system, camshaft sensor ground and signal line from other wiring(TCU system etc.). After that make a shield the separated wirings(3[cm] front of ECU) and then keep away camshaft sensor from wiring of ignition system.</p>  <p style="text-align: center;">Condenser in vehicle body connected to ECU shield</p> <p>< Optical type ></p>  <p style="text-align: center;">Connect shield wire with condenser and connect to Vehicle Body.</p> <p>< Hall type or Magnetic type ></p> |
| Engine state | During idle state, engine vibration is intermittently taken place. The backfire is occurred with LPG vehicle. |
| Signal view | <p>Crank angle signal</p>  <p>CAM angle signal</p>  <p style="color: pink; text-align: right;">Noise (Need to check injector)</p> <p>Reference: Check that ECU cut injection or ignition with noise detection. If it is not cut, ECU control is normal. C_CAM_THD is criteria for normal camshaft angle detection (About 0.5 ~ 2.5V).</p> |

5. The polarity change of camshaft sensor signal is identified with long tooth.

| | |
|-------------------------|--|
| Cause of trouble | Retarded timing or the synchronization position of camshaft signal has big difference. |
| Counter action | <p>Healing by cause of trouble</p> <p>Check whether installation position of timing belt is retarded.</p> <p>If position of timing belt is normal, adjust so that camshaft edge could be detected before recognizing long tooth signal.</p> <p><Reference></p> <p>Above 5.2 solution is an expediency and that is occurred by abnormal assembly of car manufacturer.</p> |

Engine state The lack of acceleration performance and camshaft angle sensor error is sometimes detected.

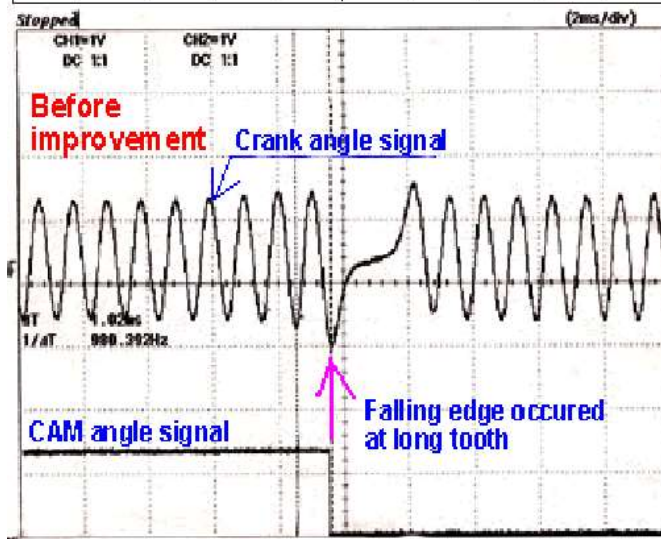
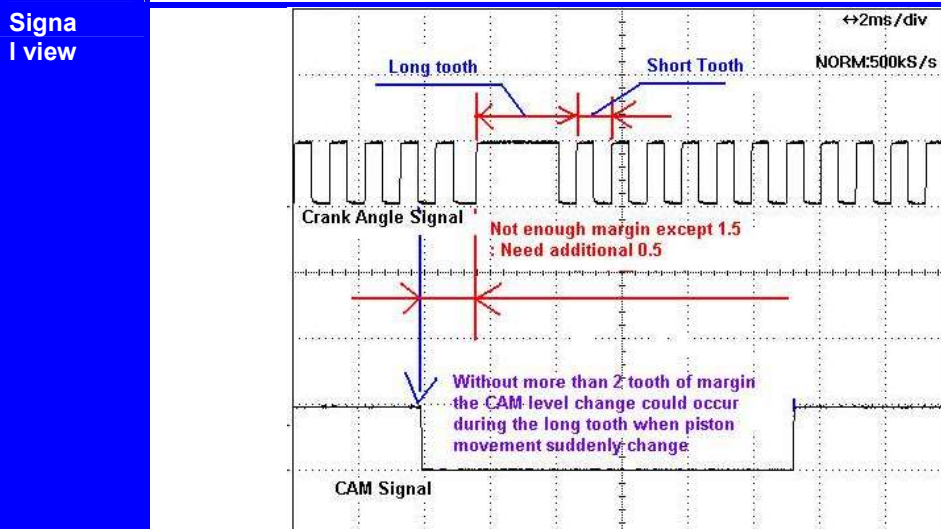

2. Field example

Vehicle : Avante 1.5L DOHC, Odometer : 48,000Km

Problem description : When acceleration during driving, the performance is lack. And trouble code of camshaft angle sensor is detected at times.

Cause : The trouble of camshaft angle sensor is due to no change of polarity between two validated long tooth. The acceleration performance is lack because camshaft sensor is assembled with 6[°CRK] retard.

Signal measurement:

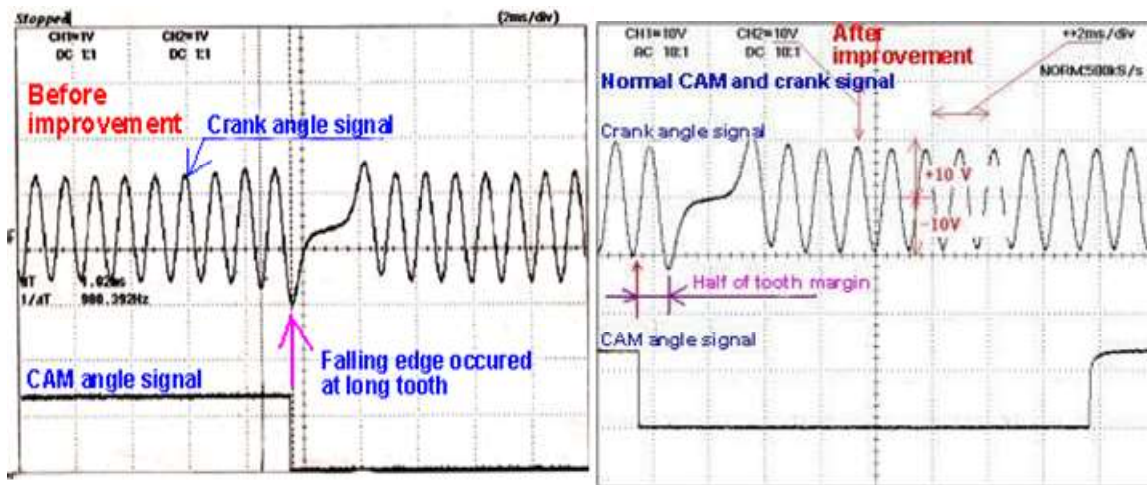

Explanation : In case that ignition timing is controlled by ECU, crankshaft and camshaft signal should exactly synchronized. Check the problem after comparing with normal crankshaft and camshaft signal.

Enlargement of application : If camshaft edge is close to long tooth detection point, it means that ignition timing is retarded. So, performance is decreased. If it is opposite case, it means that ignition is advanced and it results in knocking, lack of performance and engine damage.

3. Location of Cam Angle Sensor

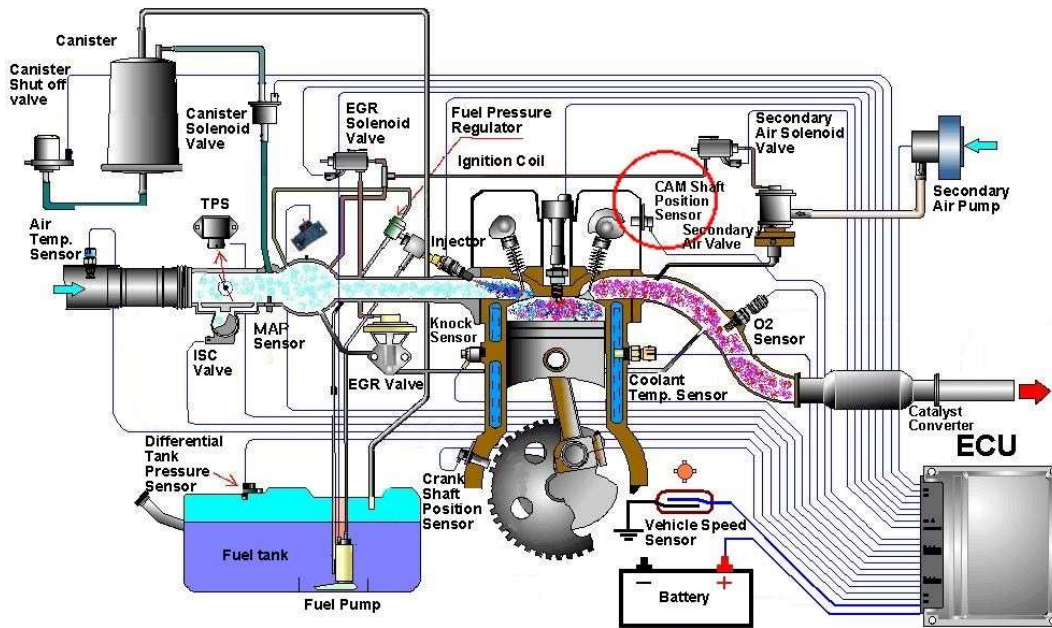

< Cam Angle Sensor : Hall / Magnetic type(left) / Optical type(right) >

4. Check method

Check trouble – **Cam angle sensor.**

Explain the Checking Method and Diagnosis of trouble..

Preparation

With connecting the Oscilloscope, Set the Sampling rate to over 250KHz and Compare the Counts and width of tooth between Long tooth after measuring the Cam Angle signal when Engine trouble is appearing.

< Reference > This signal must be measured on over 250KHz sampling rate at least to see the effect for noise. In case of low memory capacity, Measuring time is very short. Thus It must be measured on time of appearing the Engine trouble as triggering the signal. But it is difficult to catch on time of Engine trouble. At this time, Connect the Auto-Scanner. In case of connecting the Auto Scanner, there is no need to additional check trouble because Auto-scanner analyzes and Diagnose the trouble automatically.

1. Find and connect the Signal and Ground line referencing the wiring diagram.
2. After measuring the Signal, Compare the measured signal with Normal Signal.
 - (1) Find the Rising point and Falling point of Cam signal through the tooth counts of crank angle signal.
 - (2) Calculate the high and low level of cam signal as the crank angle sensor signal' s tooth counts.
3. Check if Operating of Related components with this signal are Normal through checking with the normal condition value of components.

< Related components >

1. Injector Timing and working status.
2. Ignition timing and working status

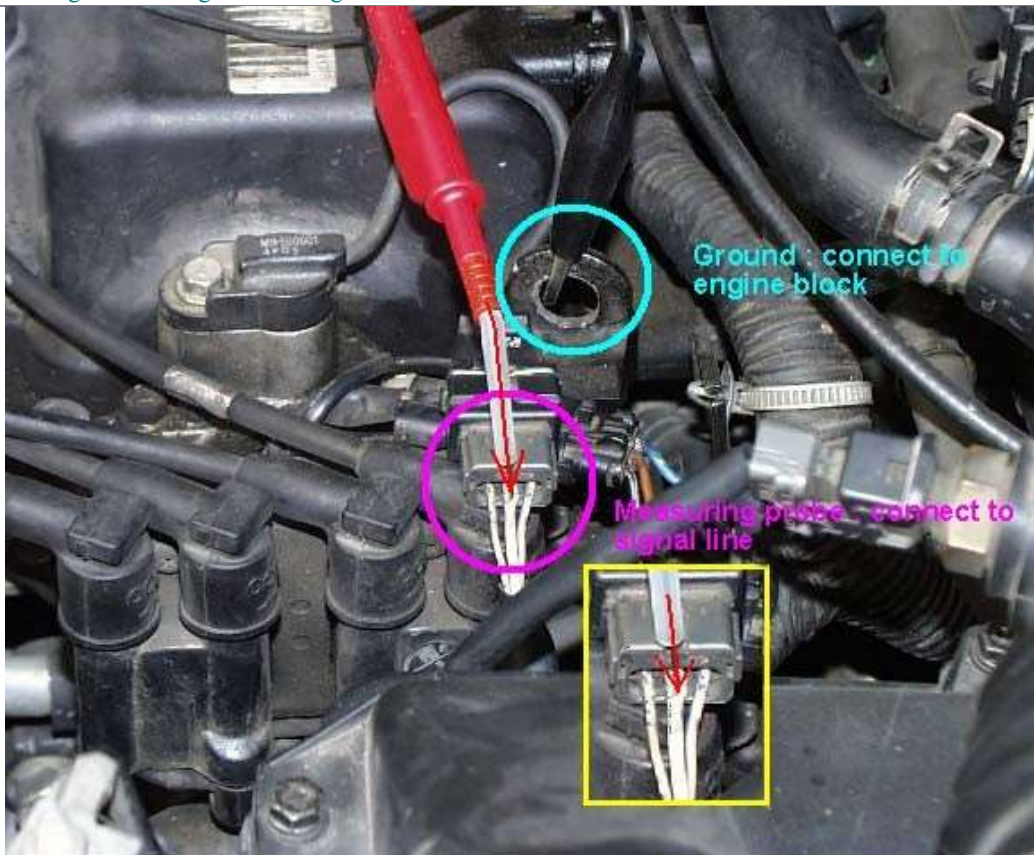

Reference : To measure the signal, ground line should be earth to chassis or engine.

5. Wave analysis

Magnetic type

Sensor signal voltage is as following graph.

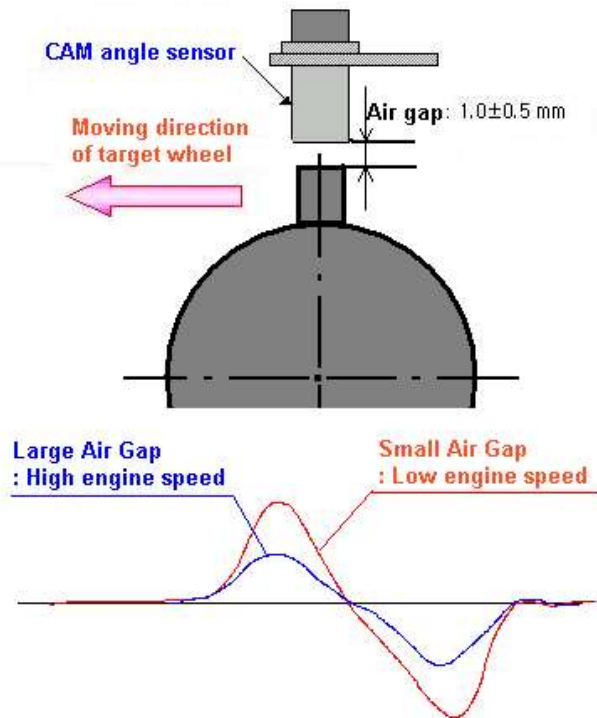

< Reference >

The high and low phase change of Cam signal must be generated before long tooth of the crank signal that is at least 3 short teeth before.

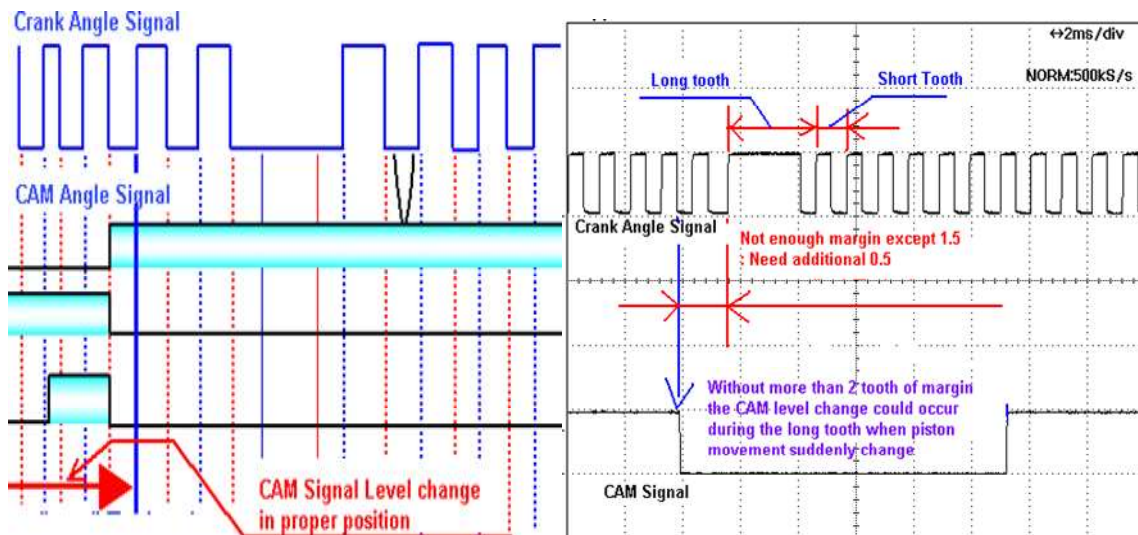

Optical type

1) This is an optical sensor. During round plate (It is called target wheel) that has holes is revolved with camshaft, the light is shone. If the light passes through the hole, out put voltage is generated. This sensor uses this principle and need power to be operated.

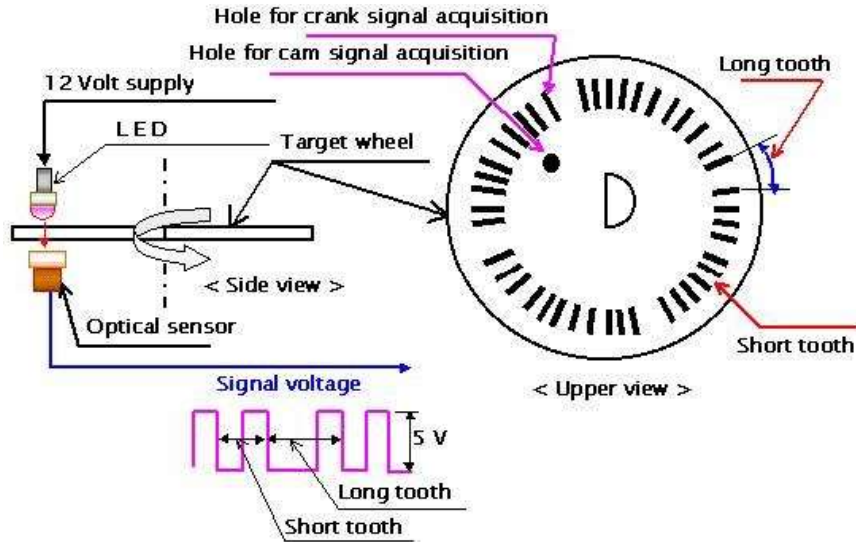

2) The level change (Edge: from high to low level/ from low to high level) of the camshaft signal must be occurred **at least two short teeth before from the long tooth**.

If the level change of the camshaft signal is occurred at long tooth or at short tooth before one tooth from the long tooth, We must check pulley (TDC) position and modify to make cam signal level change at least 2 short teeth before from the long tooth.

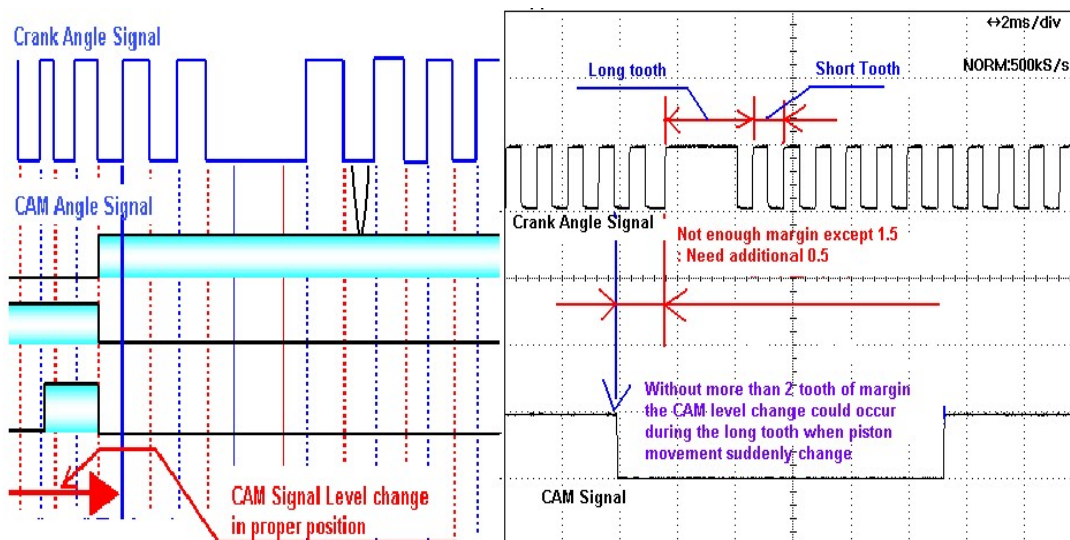

Hall type

1) This one is hall type sensor and circuit is included within sensor and 12V power is supplied. If metal is passed the sensing part within $1.0 \pm 0.5\text{mm}$ gap, 5V (someone is 12V) output voltage is generated through sensor internal circuit.

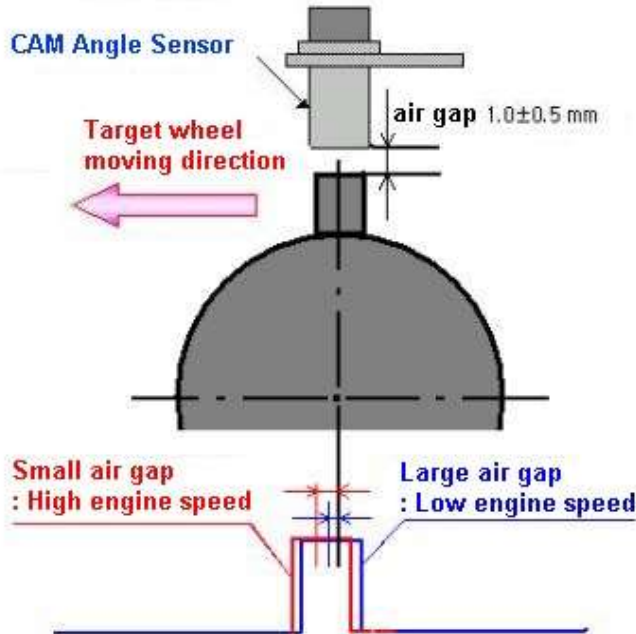

2) The level change (Edge: from high to low level/ from low to high level) of the camshaft signal must be occurred **at least two short teeth before from the long tooth.**

If the level change of the camshaft signal is occurred at long tooth or at short tooth before one tooth from the long tooth, We must check pulley (TDC) position and modify to make cam signal level change at least 2 short teeth before from the long tooth.

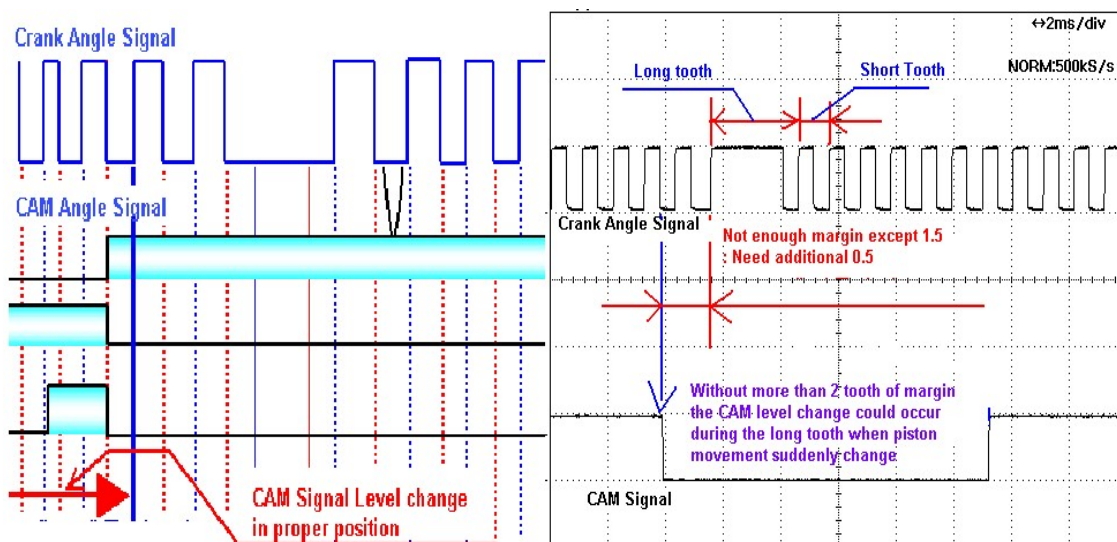

6. General

ECU can recognize the piston location from Cam angle sensor. So this sensor is called TDC sensor or phase sensor.

ECU is memorized the #1 TDC from combination of Crank and Cam angle sensor signal.

There are 3 kinds of Cam angle sensor : Optical, Hall and Magnetic type.

Optical type

This is an optical sensor. During round plate (It is called target wheel) that has holes is revolved with camshaft, the light is shone.

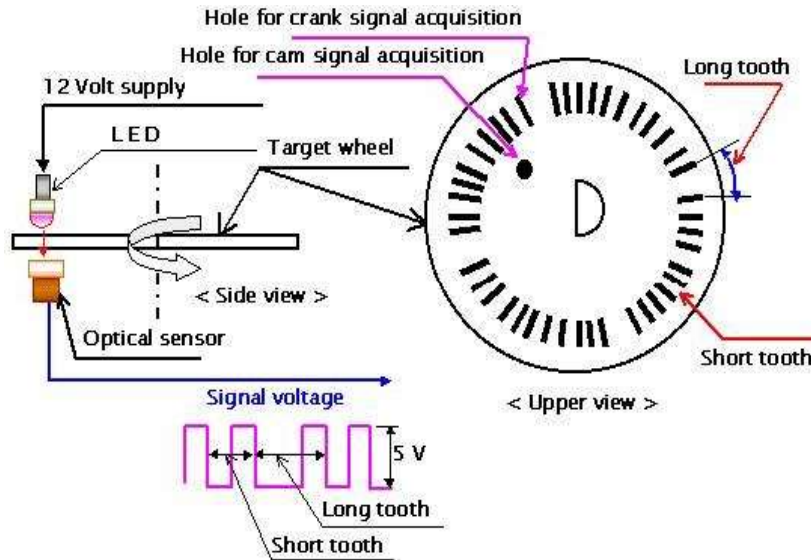

If the light passes through the hole, out put voltage is generated. This sensor uses this principle and need power to be operated. Generally this sensor is located within distributor and revolved with camshaft together. This optical sensor is weak at heat and moisture and then results in error. Most signal output is same

that of crankshaft sensor.

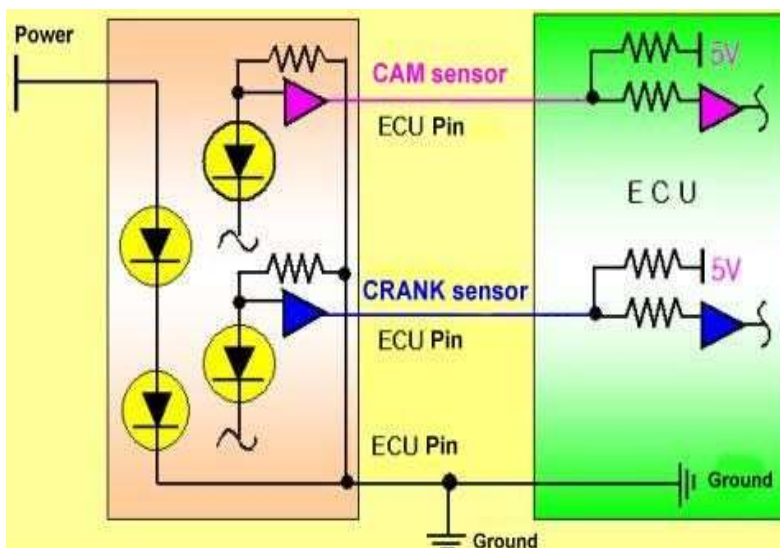

Hall type

This one is hall type sensor and circuit is included within sensor and 12V power is supplied. If metal

is passed the sensing part within $1.0 \pm 0.5\text{mm}$ gap, 5V output voltage is generated through sensor internal circuit. As a square type wheel (It is named target wheel) is assembled at flywheel that is connected to crankshaft, the sensor can get a square wave according as engine is running .

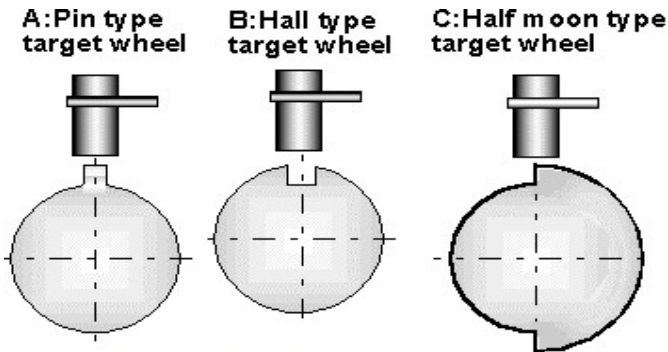

Signal(voltage) type

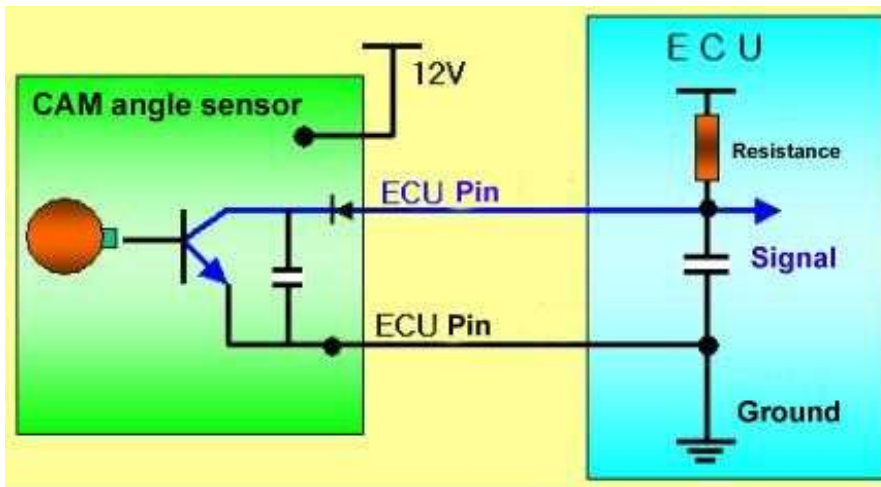
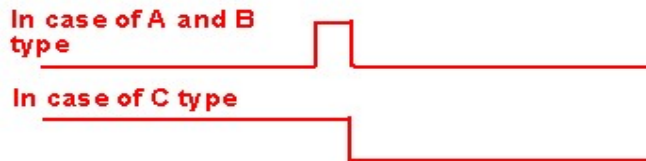

Magnetic type

Magnetic hall sensor makes magnetic line of force, thus if flywheel cuts this line during revolution

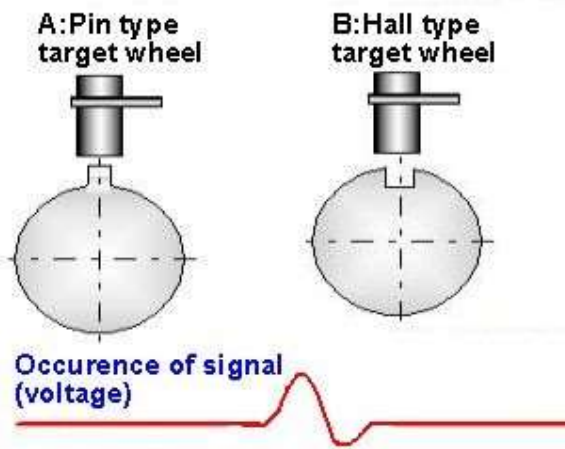

out put voltage signal is generated. The gap between sensor and flywheel must be within **1.0 ± 0.5mm**.

As a square type wheel or moon type wheel (It is called target wheel) is assembled at flywheel that is connected to camshaft, this sensor generates square type signal that repeat ON/OFF during this tooth pass sensing part. The first TDC after this signal means TDC of number 1 cylinder, so this sensor is also called number 1 TDC sensor.

7. Principle (Algorithm) comprehension

Personally, I'd like to call cam angle sensor as 'cylinder detection sensor'

CAM error can be detected often when CAM angle sensor and crank angle sensor is not synchronized correctly. If you understand why normal signal is detected as an error, there will be no problem to treat the cam angle sensor error.

Fault detection logic(algorithm)

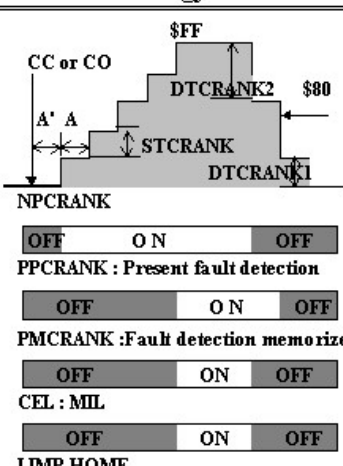
| Fault type | Detection of fault | Strategy | Code | Remark |
|-------------------------------|---|---|-------------|---|
| C O C C GND CC BAT+ | Crank angle sensor Fault detected when there are no crank angle signal during 4 CAM signals(4 engine revolutions) |  | 0002 | A' : delay for detection = 4 engine revolutions A : delay for detection = 2 engine revolutions |
| C O or C C GND C C BAT+ | CAM shaft sensor Fault detected when there are no CAM signal during 4 TDCs (2 engine revolutions) | PPMCRANK :Fault detection memorized CEL : MIL LIMP-HOME | 0003 | A, A' : delay for detection = 2 engine revolutions |

< Reference > Explanation of error detection.

As above mentioned error detection condition and logic can be changed by electric control unit developers, it must be understood as an example information otherwise you will see different cases.

For example, it is possible to make an algorithm to detect an error when Camshaft sensor signal is constant during 4 top dead center instead of 8.

First, cam angle sensor error is detected when no cam angle sensor signal is changed while crank angle sensor is shown more than 2 cycles. (more than 2 of long tooth).

That is to say, this is the answer of above question of why cam error can be detected with normal cam sensor signal when synchronization time between cam angle sensor and crank angle sensor (cam angle signal before long tooth) is incorrect. Because cam angle signal must be changed between two long tooth signal and if cam angle signal changing time is located inside of long tooth, this signal will not be detected.

Therefore, it is possible to detect cam signal when crank angle sensor is normal. And ECU sets another TDC when cam angle sensor is abnormal. Normally 19th tooth from long tooth of crank angle sensor is recognized as 1st or 4th TDC and 1st TDC is decided when cam angle signal is changed before (falling or rising signal). But if there is no cam angle sensor, it is impossible to distinguish 1st or 4th TDC.

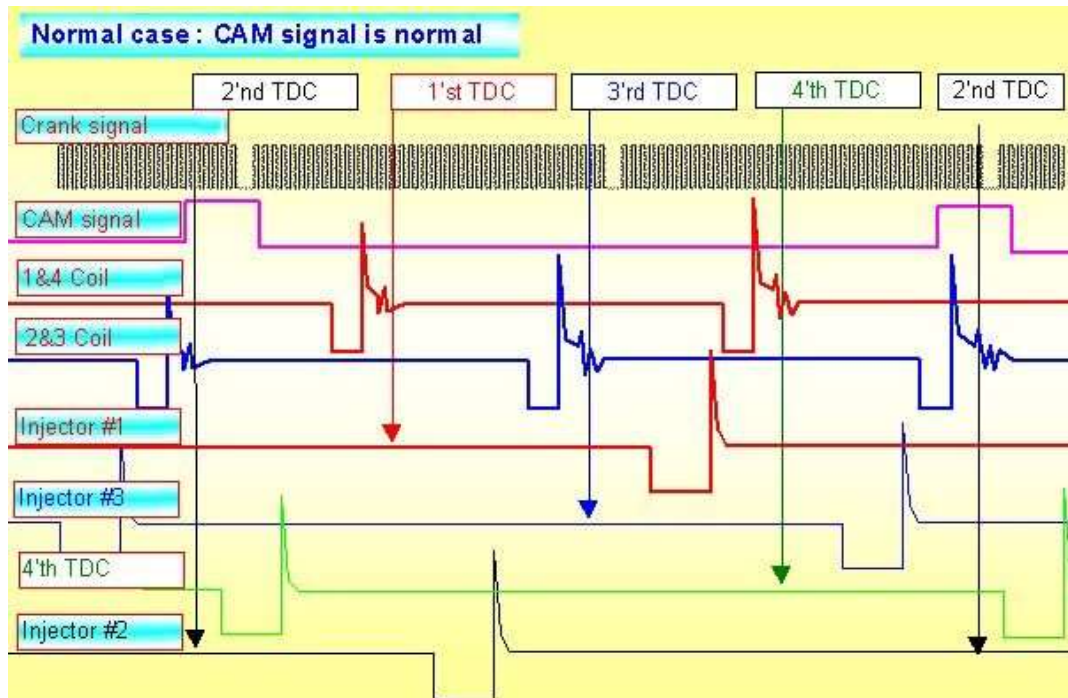

Figure 1 : Normal cam angle signal with normal injection opening.

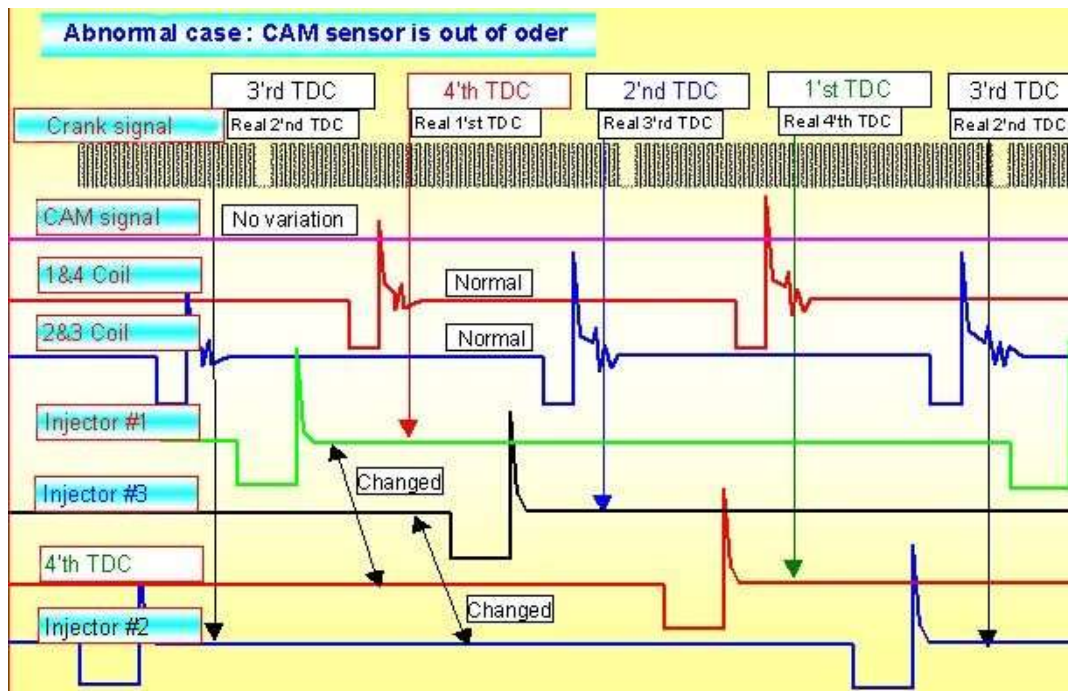

Figure 2: Injection opening with no cam angle sensor signal and injection and ignition when ECU recognized 1st TDC as 4th TDC.

According to above figure 2, we can see that ignition time is same but injection timing is different compared to figure 1.

If cam sensor failure is detected after 2nd TDC then 1st TDC is recognized for the next and after 3rd TDC, 4th

TDC is recognized for the next.

Therefore, even with cam angle sensor error there is no problem to decide TDC during engine running. But if cam sensor failure is present before engine start, 1st TDC is recognized at 19th crank angle from the long tooth and this will have 50% of probability to detect correct TDC number.

Because even with switched TDC number, there is no influence on ignition and only injection phase is changed.

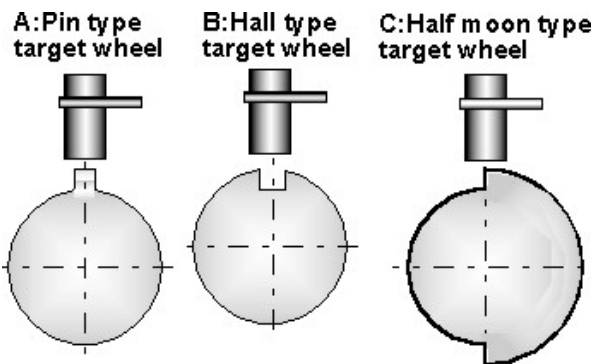
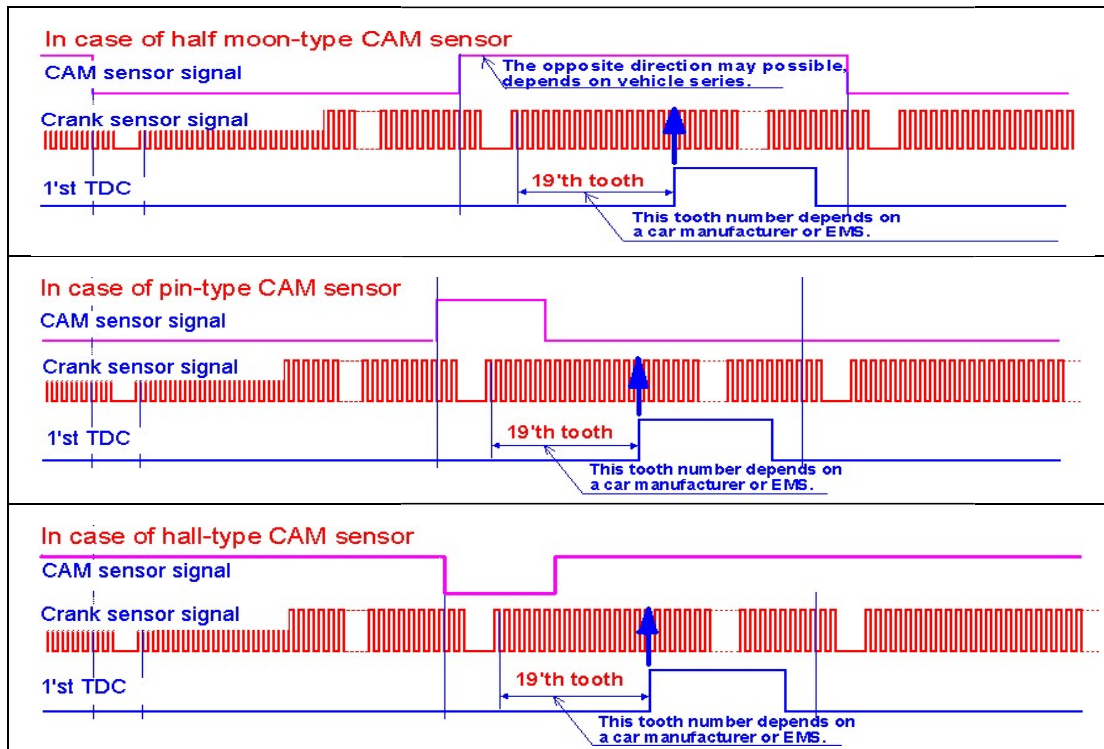

Figure 3 : Cam angle sensor signal type

There are two different type of cam angle sensor, one is optical type and the other is hall type. And some of vehicles(group injection type) do not use cam angle sensor . But cam angle sensor output signal is different depending on not sensor type but target wheel shape.

Then, if it leads only wrong injection phase (switched phase) why cam sensor is required?

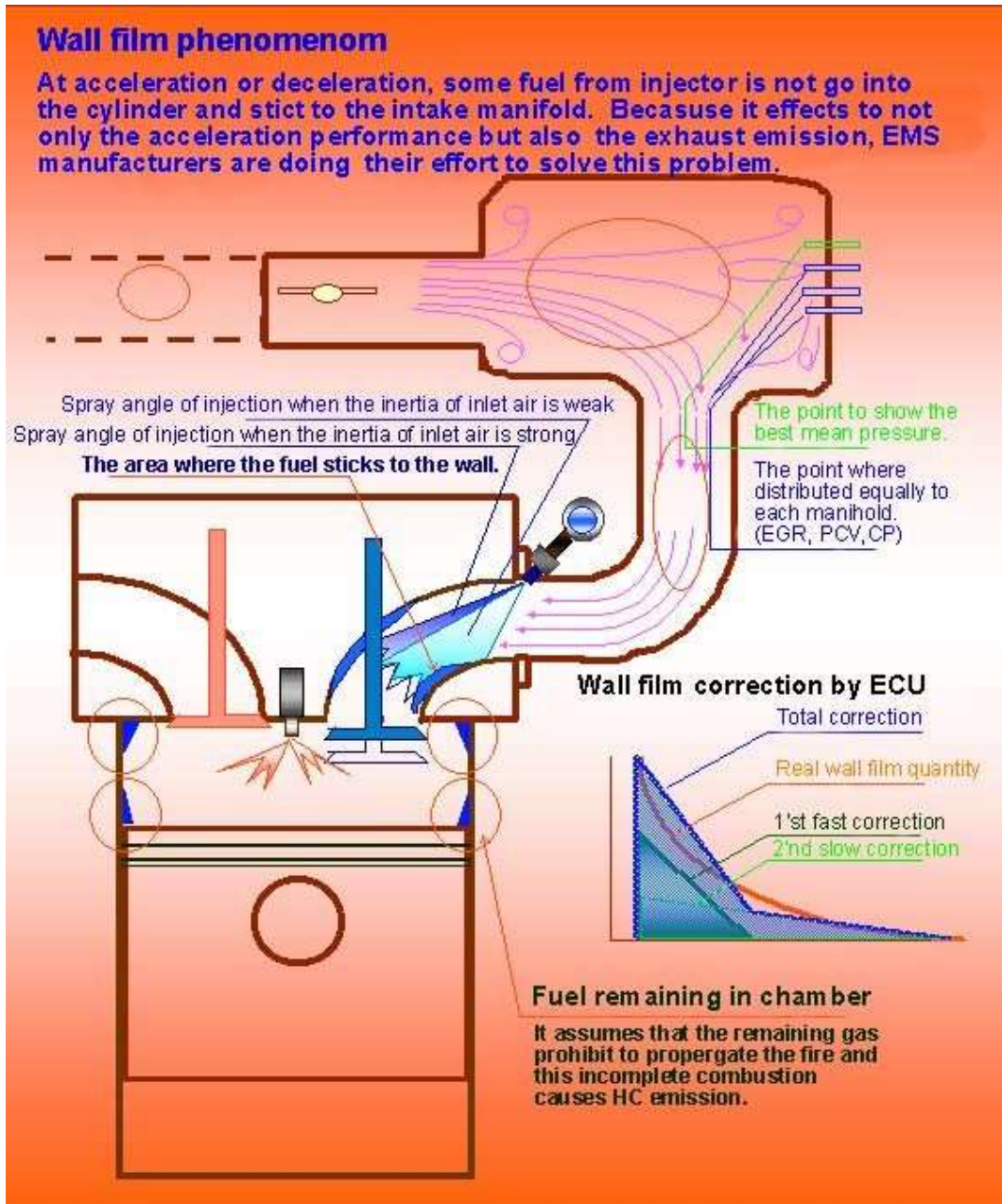

Figure 4: Wall film phenomenon

The wall film phenomenon is that inside of intake is wetted by injected fuel from injection before it goes into the cylinder. And due to this wall film, lean fuel during acceleration and rich fuel during deceleration is occurred.

One of the purposes of cam angle sensor is to prevent rich or lean fuel during acceleration or deceleration by wall film.

And if we arrange in a row other purpose of cam angle sensor.,

First: To reduce wall film during deceleration or acceleration.

As the intake manifold pressure increases during acceleration, the under-pressure in the cylinder to suck the fuel is getting smaller and fuel wetted on the intake inside is also increasing. This phenomenon leads to leakage of fuel into the cylinder. But on the contrary, intake manifold pressure decreases during deceleration and cylinder under-pressure is getting bigger and fuel on the intake inside is sucked into the cylinder and this leads to rich mixture. It is needed to reduce fuel quantity depending on injection timing.

Especially, in case of TCS (Throttle Valve Control System), if we push the throttle pedal, the required air quantity (engine torque) is predicted by TPS signal and engine speed and fuel is injected first and then the throttle valve is opened to reduce (or compensate) wall film. As the air conditioner works after compensation of required air when we switch on the air conditioner, the throttle valve is opened after fuel compensation for wall film in the TCS. But in case of cam sensor failure, there will be some engine speed hesitation or some shocks at acceleration due to incorrect fuel correction.

Second : To improve the purpose of injected fuel at each engine operating conditions.

- (1) Engine start : In case of about -20°C , engine startability depends on injection phase. So, injection phase is decided after test. Therefore, if it is impossible to detect cylinder number then it is impossible to inject fuel on exact timing too. It is for the purpose of deciding injection timing for good combustion or to avoid spark plug wetting by injected fuel.
- (2) The purpose of general mode (out of engine start and full load area) is to reduce emission. Fuel vaporization is depending on injection end timing. Fuel injected at proper timing will be vaporized well by heated intake valve and be burnt well in the cylinder. For that reason, most of cases injection is finished before intake valve opens. The good injection timing for good engine start is decided by test.
- (3) The purpose of power area is to increase torque or to speed up. The end of injection timing for fast acceleration response or for higher engine torque is decided by test. If injection time is too long then injection phase is ignored to get correct injection time.
- (4) Engine idle : Engine speed must be stable in idle but in case of high emission vehicle, above (2) is the purpose.

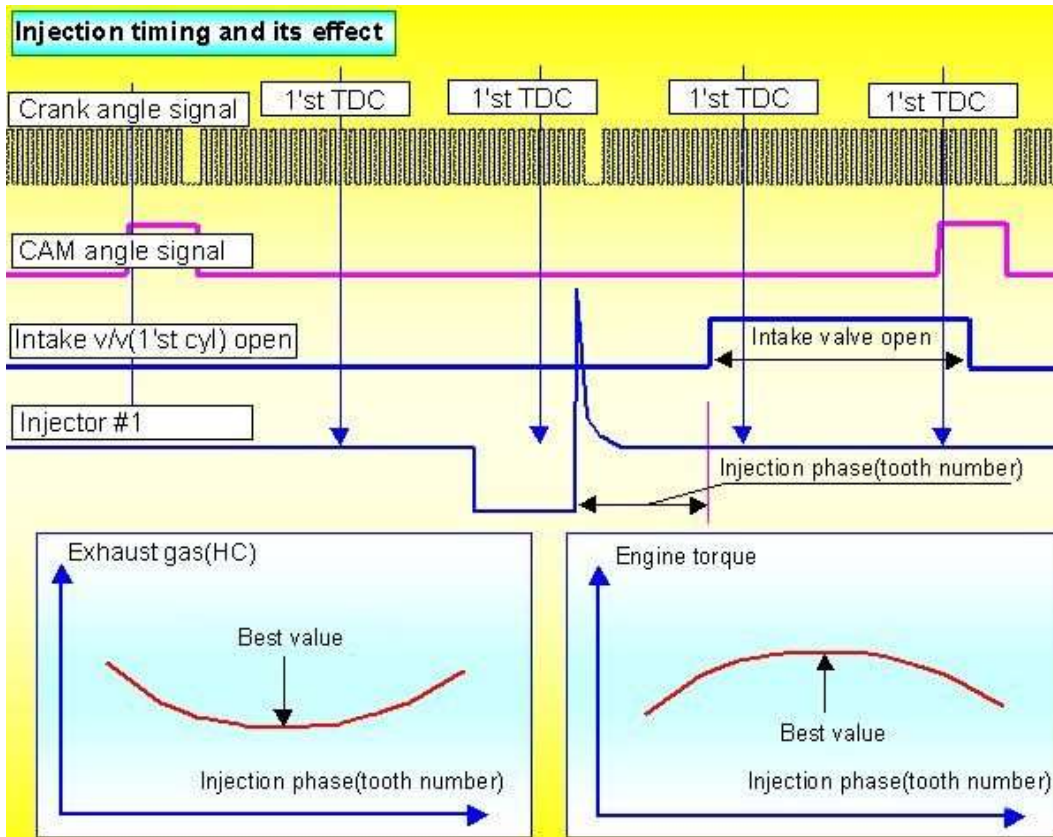

Figure5: Effect by injection phase.

The purpose of cam angle sensor is finally to detect cylinder number for the exact injection timing. Then, what if cam angle sensor is out of order?

1. In case of no cam angle sensor signal.

Phenomenon: As it can not recognize cylinder number, acceleration response can be late or emission can be increase a little. Some of vehicles case, engine vibration is increased in idle and emission is increased about 20%.

Especially, in case of TCS(Throttle Control System), big shocks can be happened at acceleration phase.

Countermeasure: Fix short circuit of sensor signal line.

2. In case of noise on the cam angle signal that is to say more than 2 of cam signal during one cycle.

Phenomenon:

- (1) If ECU ignore noise signal to detect cylinder number.(most of case) : As cam signal is ignored and cylinder recognition is continued using previous cylinder number.
- (2) In case of injection stop until normal signal.

Phenomenon:, sporadic big shocks or engine stall can be happened due to injection cut off as shown below picture.

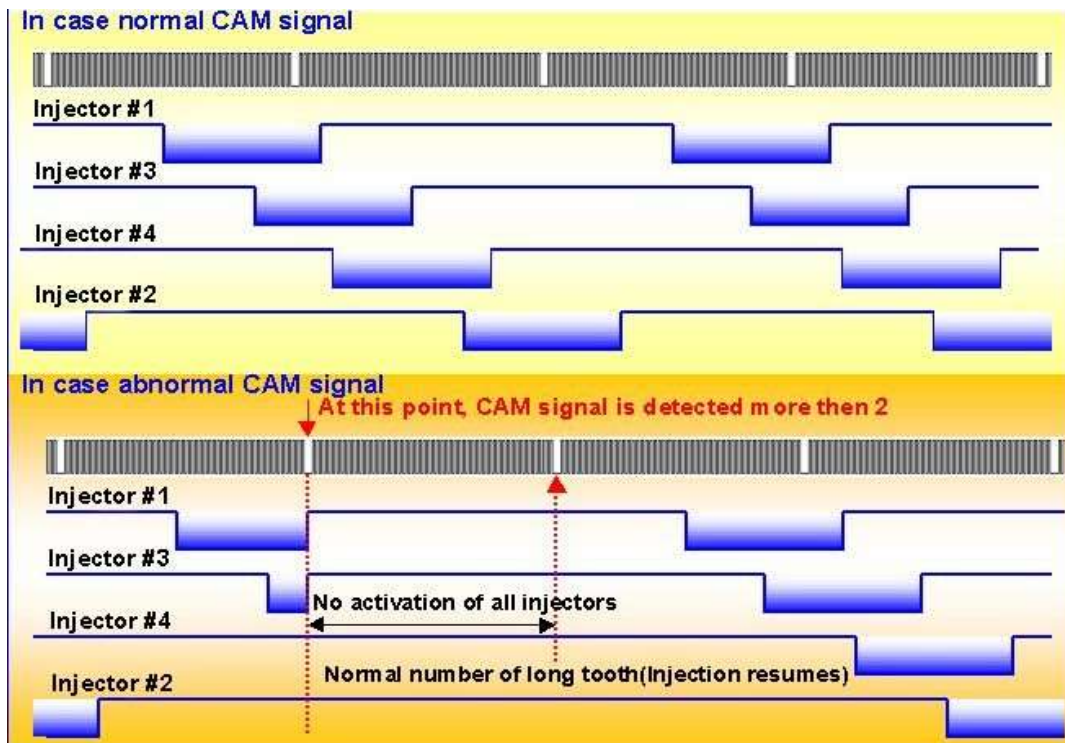

Figure 6 : Injection stop due to abnormal cam signal number.

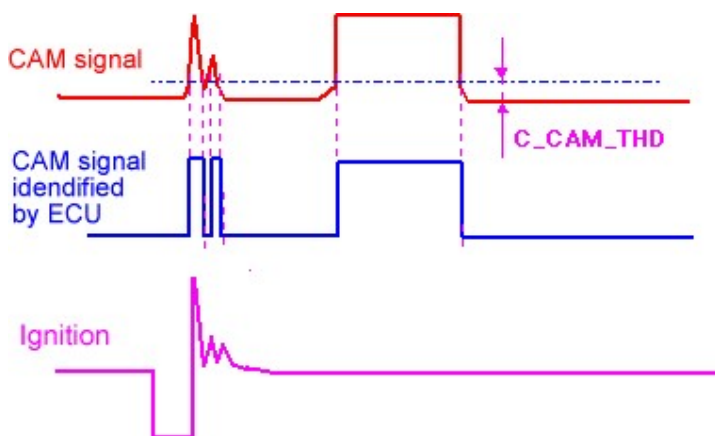

Figure 7 : In case of noise on the cam signal.

noise. If there is an ignition noise during signal falling or rising, this noise will be detected as a real tooth signal and will make some troubles (fuel cut off for a while)

General reason of noise is the ignition as shown figure 7. The counteraction for this noise is to set up the cam sensor signal line close to the ECU (within 3cm) and make shield for ignition line. And it is better to set the cam angle sensor line in the distance of ignition line.

Remark :

In case of optical type (signal is generated when light passes through the ole), it is easy to be influenced by

Figure 8: Cam angle signal recognition by noise in the optical type.

